



Chevrolet Warranty and Service Book



Introduction

Service and warranty booklet

The service and warranty booklet belongs to your vehicle and should therefore remain inside the vehicle when you sell it on.

It contains the applicable warranty conditions for your Chevrolet, documentation on the service and maintenance work carried out and work done by Chevrolet Assistance in the event of a breakdown.

Please have this booklet with you whenever you bring your vehicle to the workshop for maintenance. Proof of all service checks and work carried out in accordance with the work specifications is required if any warranty claims are to be met, and is also advantageous when selling on the vehicle.

Our service staff work with the most modern workshop and diagnostics devices and are familiar with the specific service requirements of our Chevrolet vehicles. In addition, the technical equipment in our workshops is always kept fully up to date.

Therefore, we recommend that you use Chevrolet original parts and accessories and ensure that they are fitted correctly by a Chevrolet Partner.

Chevrolet reserves the exclusive right to modify or supplement this service and warranty booklet.

Chevrolet

International Warranty Certificate

1st owner

Vehicle model

Vehicle identification number

Customer name/number

Registration plate number

Location, date

Stamp and signature of supplying
Chevrolet Partner

This document entitles you to commission any Chevrolet Partner in Europe to carry out service checks and warranty work.

The warranty comes into force at the time of delivery or first registration, whichever occurs first.

2nd owner

Customer name/number

Registration plate number

3rd owner

Customer name/number

Registration plate number

4th owner

Customer name/number

Registration plate number

Pre-Delivery Inspection

Pre-delivery inspection and vehicle delivery

Before delivering the vehicle, we carried out a thorough pre-delivery inspection in order to ensure that your Chevrolet vehicle is in proper operating condition.

We have provided you with information on the service intervals, engine oil changes, required oil level checks and handed over the pre-delivery inspection checklist.

Vehicle Data

Model

Vehicle identification number

Engine type, number

Transmission

Colour, code

Upholstery, code

Vehicle Data

Key number

Date of first registration

Prepared by

Chevrolet Partner who made the delivery

Chevrolet Partner number

Location

Date

Stamp and signature of supplying
Chevrolet Partner

Chevrolet Warranty and Service Booklet

New Vehicle Limited Warranty	1
Chevrolet warranty terms	1
Warranty for new Chevrolet vehicles.....	1
Scope of the warranty	3
Exclusions from warranty	3
Warranty against rust perforation	5
Geographic Coverage	7
Maintenance Records	8
Service confirmation	8
Additional engine oil and filter change.....	12
Corrosion protection service.....	14

Chevrolet warranty terms

This warranty provided by Chevrolet does not adversely affect the statutory rights* of the purchaser against the seller and gives remedies in addition to those against the seller under the contract of sale. Claims by the purchaser, in particular for a defect on a vehicle, against the selling Chevrolet Partner, remain unaffected by the warranty.

** May differ depending on the country of sale. Refer to a contract of sale for details (which may supersede these warranty terms).*

Warranty for new Chevrolet vehicles

General warranty

General Motors Overseas Distribution
Limited
100 Renaissance Center
Detroit, MI
USA

(referred to herein as "Chevrolet") guarantees for motor vehicles of its manufacture, that each vehicle is free from defects for a period of 36 months/100 000 km.

The warranty is valid from delivery from the supplying Chevrolet Partner or from first registration, whichever occurs first (warranty start date).

Two-Stage satisfaction procedure

Your satisfaction is important to your Partner and to Chevrolet.

Normally, any concerns with the sales transaction or the operation of your vehicle will be resolved by your Partner's sales or service departments. If your concern has not been resolved to your satisfaction, the following steps should be taken:

1. Discuss your concern with a member of the Partner or service centre management. Concerns can often be quickly resolved at that level. If the

concern has already been reviewed with the sales or service manager, contact the owner of the Partnership or the general manager.

2. if your concern cannot be resolved quickly by the dealer, please feel free to reach out to us at warranty@support.aecsv.com

Mailing Address:

AEC Specialty Vehicles Ltd.
250 Martindale Rd
St. Catharines, ON L2S 0B2
Canada
E-mail: contact@aecsv.com

2 New Vehicle Limited Warranty

General Rules for the warranty provided herein

The warranty is linked to the vehicle and continues to apply if the owner changes.

All warranty claims will expire at the end of the warranty period. For a warranty issue reported within the warranty period but not repaired by its expiry, the warranty period for this issue is extended until repair of this issue. If the issue could not be demonstrated or the presence of the issue or its repair is disputed, the warranty expires two months after the last repair or declaration by the Chevrolet Partner or Chevrolet that the fault has been eliminated or no fault is present. An interruption or restart of the warranty period by repair or checking of the issue or negotiations on circumstances justifying the claim is excluded.

Promises by third parties of any type which deviate in any way from the scope and conditions of warranty described here are not binding on Chevrolet.

Scope of the warranty

General

- A. The warranty applies exclusively to free of charge repair of the vehicle by a Chevrolet Partner, i.e. Chevrolet's obligations under this warranty are limited to repairing or replacing at its option any parts by a Chevrolet Partner.
The repair or replacement of defective parts will be made by the Partner to whom the vehicle is returned, without charge for parts and labour.
- B. For the parts fitted during a repair, until expiry of the warranty period according to paragraph 1, the same warranty is given as for the motor vehicle, i.e. the warranty is not extended by the repair or replacement of parts even for the parts rectified or replaced. No further claims can be made on the basis of the warranty. Replaced parts become the property of Chevrolet.
- C. Warranty claims can only be made on presentation of the service and warranty

booklet with confirmed services and the warranty certificate completed and signed by the supplying Chevrolet Partner.

- D. Chevrolet reserves the right to appoint its engineer to inspect the vehicle prior to any repair or replacement of parts covered.
- E. The warranty is valid until express confirmation by Chevrolet, only under the condition that, in the context of any subsequent inspections (e.g. parts inspections), the legitimacy of the warranty claim is confirmed. If the inspection indicates that this is not a case of warranty repair, the costs shall be borne by the commissioner.

Exclusions from warranty

Scheduled/non-scheduled maintenance, consumable items

Routine service and maintenance are not covered by the warranty. Replacement of maintenance items, including but not limited to filters, gaskets and sundry items or

replenishment of consumable fluids, including but not limited to: oils, gases, coolant, brake fluid, windscreen wash solution and antifreeze, is covered only when they are used as part of a warranty repair on a different component, provided they are not due for replacement under the requirements of the service schedules.

The following items are considered as maintenance items but have been excluded from regular service schedules because the frequency of their replacement will vary dependent on the operating conditions of the vehicle:

- wheel balancing and alignment
- regeneration of diesel particle filter
- aligning body components such as strikers and hinges
- elimination of vibration noises caused by body parts or misalignment of body, wheels or suspension
- adjustment of the following:
 - brakes
 - handbrake
 - clutch

4 New Vehicle Limited Warranty

- gear stick
- ribbed V-belts
- ignition
- engine timing
- headlights
- front wheel geometry
- doors
- bonnet
- tailgate
- flaps
- sunroof
- windows

Wear and tear items

Natural wear of any component is excluded from the warranty. Depending on operating conditions and the owner's driving habits, additional wear and tear of components may take place and the rectification of any faults generated in this way are considered not to be covered by the warranty.

The following components are generally considered wear and tear items and therefore excluded from warranty:

- brake linings, brake drums, brake disc and brake pads
- clutch release bearings, clutch pressure plates and centre plates
- tyres
- wiper blades and rubbers
- auxiliary drive belts
- toothed belts and ribbed V-belts
- interior/exterior trims, mouldings, weather strips
- seat and backrest covers
- floor coverings
- glass breakage (due to external influence)
- heated window elements (due to damage)
- spark plugs
- exhaust pipes and silencers
- batteries for radio remote controls
- fuses
- light bulbs excluding Xenon headlamp bulbs
- gas springs for tailgate and bonnet
- shock absorbers and MacPherson struts

Other exclusions

Warranty claims are further excluded

- A. if the services (inspections according to the Chevrolet service plan) specified

by Chevrolet or other repairs are not performed on time or not in accordance with Chevrolet's specifications. The exclusion does not apply where proof has been provided that the damage was not caused by the omitted or delayed service. Services performed must be documented;

- B. for assemblies which are directly or indirectly affected by parts (e.g. tuning or styling parts) subsequently fitted to the motor vehicle and which do not form part of the original Chevrolet accessories, or if the motor vehicle has been modified in a manner not approved by Chevrolet;
- C. if the vehicle, without the prior approval of Chevrolet, was filled with fuel of incorrect specification, including so-called biodiesel and the resulting damage affects vehicle components, the function of which could be adversely affected by filling with fuel of incorrect specification. The same applies for operation with operating fluids of incorrect specification, e.g. engine oil;
- D. if the motor vehicle has been used for competitions, races, rallies, record attempts or similar sports events or

activities, or used off-road unless approved by Chevrolet;

- E. if the vehicle identification number of the motor vehicle has been altered or removed or if it cannot be identified or does not correspond to the data present in this service and warranty booklet;
- F. for sealed components, if the seal is broken;
- G. for breakdown or damage to parts (whether guaranteed or not) caused by frost, water, blockages due to freezing liquids, contaminants building up, sludge or silt, or other waste matter that has prevented the parts from working properly;
- H. if the odometer has been tampered with, altered or disconnected.

This warranty also does not apply if the original cause of a defect stems from

- A. a failure to observe Chevrolet specifications on care and treatment of the vehicle (e.g. as specified in the Owner's Manual) including but not limited to omission of taking appropriate action in

the event of warning lights appearing or failure to correct detected defects;

- B. repair or servicing of the motor vehicle not performed by a Chevrolet Partner;
- C. improper handling or overloading of the motor vehicle;
- D. external mechanical or chemical influences have affected the motor vehicle (in the case of paintwork or bodywork damage, in particular stone chips, rust film, industrial emissions, bird droppings); or
- E. failure to report and to rectify a defect which was already apparent during motor vehicle delivery immediately after delivery, or a defect which becomes apparent at a later date immediately after it became apparent as specified in Scope of the warranty;
- F. failure by the owner to take the expected steps to remedy the damage incurred.

For tyres, Chevrolet only provides warranty if the end customer has first claimed on the manufacturer of these products. Legal action is not required. For any conversions made

by third parties and supplied by Chevrolet or a third party, Chevrolet does not grant any warranty.

Incidental or consequential costs such as hotel charges, car hire, and loss of personal effects or income are not recoverable under the terms of the warranty.

Warranty against rust perforation

- A. Chevrolet guarantees that no rust perforation of the bodywork (corrosion from inside to outside, perforation) will occur as a result of defective materials or workmanship, providing that the vehicle has been used normally in the intended manner.
- B. The warranty is valid for a period of 6 years, from the date of delivery from the supplying Chevrolet Partner or from first registration, whichever occurs first. For Chevrolet offered body conversions the warranty is valid for a period of 3 years. The warranty is linked to the vehicle and continues to apply if the

6 New Vehicle Limited Warranty

owner changes. The service and warranty booklet must also be handed over to the next owner so that the benefit of the warranty against rust penetration is also transferred.

- C. For the parts fitted during repair, until expiry of the warranty period, the same warranty is given as for the motor vehicle, i.e. the warranty is not extended by the repair or replacement of parts even for the parts repaired or replaced. Replaced parts become the property of Chevrolet.
- D. The warranty against rust penetration is restricted to a Chevrolet Partner restoring the vehicle to a condition corresponding to the normal wear on the vehicle according to age, mileage and state of maintenance at the time of repair. If the repair costs exceed the time value of the vehicle without the rust penetration damage covered by the warranty, only the time value is remunerated.
- E. The warranty is dependent on the corrosion protection inspections specified in the service and warranty booklet having been performed without omission

by a Chevrolet Partner and being documented by corresponding entries in this service and warranty booklet, and bodywork damage found to be at risk of corrosion due to external influences being repaired within 2 months from detection by a Chevrolet Partner.

- F. Any rust damage found in the interim must be presented immediately to a Chevrolet Partner for repair. All warranty claims will expire at the end of the warranty period in accordance with 4.b. In the event of a rust penetration damage issue reported within the warranty period which is not rectified, the warranty period will continue to apply until this identified issue is rectified up to a maximum of 2 months following the end of the warranty period.
- G. Interruption or restarting of the warranty period due to repair or evaluation of the complaint or negotiations on the circumstances surrounding the complaint is excluded.

This warranty does not apply

- A. Where corrosion results from fitting parts (e.g. accessories, tuning or styling parts) which are not approved by Chevrolet or where approved parts are fitted other than in accordance with Chevrolet's instructions; or
- B. if the motor vehicle has been used for competitions, races, rallies, record attempts or similar sports events or activities or
- C. to any part of the bodywork which has suffered accidental damage, unless that damage has been repaired to the standard specified by Chevrolet, and where the repair involves the fitting of new parts, such parts are original Chevrolet parts or approved Chevrolet parts; or
- D. where corrosion results from damage to the paintwork and other protective surfaces by extraneous factors including, but not limited to, stone chips, scratches, accidental damage, atmospheric pollution or the application of corrosive materials
- E. warranty claims under the warranty against rust penetration are also not

applicable in the cases mentioned in
Other exclusions under Exclusions from
warranty.

Rectification of collision damage bodywork
and paintwork must be performed in
accordance with the Chevrolet guidelines.
For welding work on Chevrolet motor vehicles,
the Chevrolet guidelines must be observed
in order to guarantee the safety of the motor
vehicle after repair and meet the requirements
of permanent corrosion protection and
corrosion protection measures.

Geographic Coverage

Chevrolet Warranties are valid for repair
performed by a Chevrolet Partner within
the European Union, United Kingdom,
Liechtenstein, Norway and Switzerland.

AECSV ROADSIDE ASSISTANCE EUROPE

PLEASE USE THE FOLLOWING CONTACT NRS PER COUNTRY

COUNTRY	PHONE
Belgium	+32 22 86 31 67
France	+33 437 64 11 68
Germany	+49 898 39 31 18 01
Netherlands	+31 592 39 04 66
Sweden	+46 851 79 28 04

SUPPORT & LIMITATIONS

AECSV Roadside Assistance supports AECSV customers when their vehicle is immobilized as
a result of vehicle defect, accident, loss of keys, short of fuel, etc.

SUPPORT	LIMITATIONS
Help on the phone	excluded: A/C system defective, windscreen wipers missing or defective, marten bite, snow chains not fitted, water ingress, keys stolen, vandalism
Towing RSA (including off-road)	breakdown <120 km from home: to home AECSV dealer OR breakdown >120kms from home: to nearest AECSV dealer OR breakdown >120kms from AECSV dealer: to nearest alternative car dealer
Replacement vehicle	for maximum 5 working days AND same category vehicle (when available)
Accommodation	maximum 4 nights AND maximum 200 €/night (breakfast included) (Net)
Taxi	maximum 100 € (Net)
Recovery of travelers	repair >4hrs AND distance from to home >80kms AND travel method: bus, train, airplane (if journey exceeds 6 hours) AND maximum 615 €/person (Net)
Recovery / transport of unrepaired vehicle	maximum 1,500 € (Net)
Recovery / transport of unrepaired vehicle	repair >3 working days AND maximum 1,500 € (Net)

8 Maintenance Records

Service confirmation

The servicing carried out is documented on the following pages.

A service should be carried out whenever the service display indicates it but not later than according to service intervals mentioned in the Owner's Manual.

Please see the Owner's Manual for permitted engine oil qualities and engine oil viscosities.

The work is marked with yes or no

Yes: was exchanged or replaced

No: no exchange necessary

Note

Predefined details must not be altered.

Service: Interim Main

Date _____ km/mi

Engine oil

Grade: dexos 1 dexos 2

GM-LL-A-025 GM-LL-B-025

Viscosity: _____ W- _____

Anti-freeze, coolant _____ °C

Yes No

- Battery (RKE)
- Pollen Filter
- Air Cleaner Element
- Accessory Drive Belt
- Fuel Filter
- Transmission fluid
- Brake Fluid
- Tyre Inflation System/Repair Kit (if fitted)
- Brake Pads Front/Rear
- Spark Plugs
- Coolant

See Owner's Manual for any additional items.

Partner stamp and signature

Service: Interim Main

Date _____ km/mi

Engine oil

Grade: dexos 1 dexos 2

GM-LL-A-025 GM-LL-B-025

Viscosity: _____ W- _____

Anti-freeze, coolant _____ °C

Yes No

- Battery (RKE)
- Pollen Filter
- Air Cleaner Element
- Accessory Drive Belt
- Fuel Filter
- Transmission fluid
- Brake Fluid
- Tyre Inflation System/Repair Kit (if fitted)
- Brake Pads Front/Rear
- Spark Plugs
- Coolant

See Owner's Manual for any additional items.

Partner stamp and signature

Maintenance Records 9

Service: Interim Main

Date _____ km/mi

Engine oil

Grade: dexos 1 dexos 2
 GM-LL-A-025 GM-LL-B-025

Viscosity: _____W- _____

Anti-freeze, coolant _____°C

Yes No

- Battery (RKE)
- Pollen Filter
- Air Cleaner Element
- Accessory Drive Belt
- Fuel Filter
- Transmission fluid
- Brake Fluid
- Tyre Inflation System/Repair Kit (if fitted)
- Brake Pads Front/Rear
- Spark Plugs
- Coolant

See Owner's Manual for any additional items.

Partner stamp and signature

Service: Interim Main

Date _____ km/mi

Engine oil

Grade: dexos 1 dexos 2
 GM-LL-A-025 GM-LL-B-025

Viscosity: _____W- _____

Anti-freeze, coolant _____°C

Yes No

- Battery (RKE)
- Pollen Filter
- Air Cleaner Element
- Accessory Drive Belt
- Fuel Filter
- Transmission fluid
- Brake Fluid
- Tyre Inflation System/Repair Kit (if fitted)
- Brake Pads Front/Rear
- Spark Plugs
- Coolant

See Owner's Manual for any additional items.

Partner stamp and signature

Service: Interim Main

Date _____ km/mi

Engine oil

Grade: dexos 1 dexos 2
 GM-LL-A-025 GM-LL-B-025

Viscosity: _____W- _____

Anti-freeze, coolant _____°C

Yes No

- Battery (RKE)
- Pollen Filter
- Air Cleaner Element
- Accessory Drive Belt
- Fuel Filter
- Transmission fluid
- Brake Fluid
- Tyre Inflation System/Repair Kit (if fitted)
- Brake Pads Front/Rear
- Spark Plugs
- Coolant

See Owner's Manual for any additional items.

Partner stamp and signature

10 Maintenance Records

Service: Interim Main

Date _____ km/mi

Engine oil

Grade: dexos 1 dexos 2
GM-LL-A-025 GM-LL-B-025

Viscosity: _____ W- _____

Anti-freeze, coolant _____ °C

Yes No

- Battery (RKE)
- Pollen Filter
- Air Cleaner Element
- Accessory Drive Belt
- Fuel Filter
- Transmission fluid
- Brake Fluid
- Tyre Inflation System/Repair Kit (if fitted)
- Brake Pads Front/Rear
- Spark Plugs
- Coolant

See Owner's Manual for any additional items.

Partner stamp and signature

Service: Interim Main

Date _____ km/mi

Engine oil

Grade: dexos 1 dexos 2
GM-LL-A-025 GM-LL-B-025

Viscosity: _____ W- _____

Anti-freeze, coolant _____ °C

Yes No

- Battery (RKE)
- Pollen Filter
- Air Cleaner Element
- Accessory Drive Belt
- Fuel Filter
- Transmission fluid
- Brake Fluid
- Tyre Inflation System/Repair Kit (if fitted)
- Brake Pads Front/Rear
- Spark Plugs
- Coolant

See Owner's Manual for any additional items.

Partner stamp and signature

Service: Interim Main

Date _____ km/mi

Engine oil

Grade: dexos 1 dexos 2
GM-LL-A-025 GM-LL-B-025

Viscosity: _____ W- _____

Anti-freeze, coolant _____ °C

Yes No

- Battery (RKE)
- Pollen Filter
- Air Cleaner Element
- Accessory Drive Belt
- Fuel Filter
- Transmission fluid
- Brake Fluid
- Tyre Inflation System/Repair Kit (if fitted)
- Brake Pads Front/Rear
- Spark Plugs
- Coolant

See Owner's Manual for any additional items.

Partner stamp and signature

Service: Interim Main
 Date km/mi

Engine oil

Grade: dexos 1 dexos 2
 GM-LL-A-025 GM-LL-B-025

Viscosity: _____W- _____

Anti-freeze, coolant _____°C

Yes No

- Battery (RKE)
- Pollen Filter
- Air Cleaner Element
- Accessory Drive Belt
- Fuel Filter
- Transmission fluid
- Brake Fluid
- Tyre Inflation System/Repair Kit (if fitted)
- Brake Pads Front/Rear
- Spark Plugs
- Coolant

See Owner's Manual for any additional items.

Partner stamp and signature

Service: Interim Main
 Date km/mi

Engine oil

Grade: dexos 1 dexos 2
 GM-LL-A-025 GM-LL-B-025

Viscosity: _____W- _____

Anti-freeze, coolant _____°C

Yes No

- Battery (RKE)
- Pollen Filter
- Air Cleaner Element
- Accessory Drive Belt
- Fuel Filter
- Transmission fluid
- Brake Fluid
- Tyre Inflation System/Repair Kit (if fitted)
- Brake Pads Front/Rear
- Spark Plugs
- Coolant

See Owner's Manual for any additional items.

Partner stamp and signature

Service: Interim Main
 Date km/mi

Engine oil

Grade: dexos 1 dexos 2
 GM-LL-A-025 GM-LL-B-025

Viscosity: _____W- _____

Anti-freeze, coolant _____°C

Yes No

- Battery (RKE)
- Pollen Filter
- Air Cleaner Element
- Accessory Drive Belt
- Fuel Filter
- Transmission fluid
- Brake Fluid
- Tyre Inflation System/Repair Kit (if fitted)
- Brake Pads Front/Rear
- Spark Plugs
- Coolant

See Owner's Manual for any additional items.

Partner stamp and signature

12 Maintenance Records

Service: Interim Main

Date _____ km/mi

Engine oil

Grade: dexos 1 dexos 2
GM-LL-A-025 GM-LL-B-025

Viscosity: _____W- _____

Anti-freeze, coolant _____°C

Yes No

- Battery (RKE)
- Pollen Filter
- Air Cleaner Element
- Accessory Drive Belt
- Fuel Filter
- Transmission fluid
- Brake Fluid
- Tyre Inflation System/Repair Kit (if fitted)
- Brake Pads Front/Rear
- Spark Plugs
- Coolant

See Owner's Manual for any additional items.

Partner stamp and signature

Service: Interim Main

Date _____ km/mi

Engine oil

Grade: dexos 1 dexos 2
GM-LL-A-025 GM-LL-B-025

Viscosity: _____W- _____

Anti-freeze, coolant _____°C

Yes No

- Battery (RKE)
- Pollen Filter
- Air Cleaner Element
- Accessory Drive Belt
- Fuel Filter
- Transmission fluid
- Brake Fluid
- Tyre Inflation System/Repair Kit (if fitted)
- Brake Pads Front/Rear
- Spark Plugs
- Coolant

See Owner's Manual for any additional items.

Partner stamp and signature

Additional engine oil and filter change

Please see the Owner's Manual for permitted engine oil qualities and engine oil viscosities.

Date _____ km

Engine oil

Grade: dexos 1 dexos 2
GM-LL-A-025 GM-LL-B-025

Viscosity: _____W- _____

Diesel fuel filter:

replace or drain water

Partner stamp and signature

Date _____ km/mi

Engine oil

Grade: dexos 1 dexos 2
GM-LL-A-025 GM-LL-B-025

Viscosity: _____W- _____

Diesel fuel filter:

replace or drain water

Partner stamp and signature

Date	km		
Engine oil			
Grade:	dexos 1 <input type="checkbox"/>	dexos 2 <input type="checkbox"/>	
	GM-LL-A-025 <input type="checkbox"/>	GM-LL-B-025 <input type="checkbox"/>	
Viscosity:	_____W- _____		
Diesel fuel filter:			
replace or drain water			<input type="checkbox"/>
Partner stamp and signature			

Date	km		
Engine oil			
Grade:	dexos 1 <input type="checkbox"/>	dexos 2 <input type="checkbox"/>	
	GM-LL-A-025 <input type="checkbox"/>	GM-LL-B-025 <input type="checkbox"/>	
Viscosity:	_____W- _____		
Diesel fuel filter:			
replace or drain water			<input type="checkbox"/>
Partner stamp and signature			

Date	km		
Engine oil			
Grade:	dexos 1 <input type="checkbox"/>	dexos 2 <input type="checkbox"/>	
	GM-LL-A-025 <input type="checkbox"/>	GM-LL-B-025 <input type="checkbox"/>	
Viscosity:	_____W- _____		
Diesel fuel filter:			
replace or drain water			<input type="checkbox"/>
Partner stamp and signature			

Date	km/mi		
Engine oil			
Grade:	dexos 1 <input type="checkbox"/>	dexos 2 <input type="checkbox"/>	
	GM-LL-A-025 <input type="checkbox"/>	GM-LL-B-025 <input type="checkbox"/>	
Viscosity:	_____W- _____		
Diesel fuel filter:			
replace or drain water			<input type="checkbox"/>
Partner stamp and signature			

Date	km/mi		
Engine oil			
Grade:	dexos 1 <input type="checkbox"/>	dexos 2 <input type="checkbox"/>	
	GM-LL-A-025 <input type="checkbox"/>	GM-LL-B-025 <input type="checkbox"/>	
Viscosity:	_____W- _____		
Diesel fuel filter:			
replace or drain water			<input type="checkbox"/>
Partner stamp and signature			

Date	km/mi		
Engine oil			
Grade:	dexos 1 <input type="checkbox"/>	dexos 2 <input type="checkbox"/>	
	GM-LL-A-025 <input type="checkbox"/>	GM-LL-B-025 <input type="checkbox"/>	
Viscosity:	_____W- _____		
Diesel fuel filter:			
replace or drain water			<input type="checkbox"/>
Partner stamp and signature			

14 Maintenance Records

Date	km			
Engine oil				
Grade:	dexos 1	<input type="checkbox"/>	dexos 2	<input type="checkbox"/>
	GM-LL-A-025	<input type="checkbox"/>	GM-LL-B-025	<input type="checkbox"/>
Viscosity:	_____W-		_____	
Diesel fuel filter:				
replace or drain water	<input type="checkbox"/>			
Partner stamp and signature				

Date	km/mi			
Engine oil				
Grade:	dexos 1	<input type="checkbox"/>	dexos 2	<input type="checkbox"/>
	GM-LL-A-025	<input type="checkbox"/>	GM-LL-B-025	<input type="checkbox"/>
Viscosity:	_____W-		_____	
Diesel fuel filter:				
replace or drain water	<input type="checkbox"/>			
Partner stamp and signature				

Corrosion protection service

Body and underbody corrosion protection service

To maintain the Chevrolet warranty against corrosion, the vehicle must be subjected to an inspection by a Chevrolet Partner every 12 months.

The vehicle must be submitted to the workshop in a clean state so that the corrosion protection service can be carried out. Please bear in mind that this applies to the underbody, wheel arches, etc., as well as to the outside of the vehicle. If you are unsure about this point, we recommend that you seek the advice of your Chevrolet Partner in advance.

All paint damage must be repaired before the corrosion protection service by a paint and bodyshop in accordance with guidelines issued by Chevrolet.

To maintain the warranty, all prescribed corrosion protection services must be confirmed in the relevant form on the following pages.

Recommendations for collision damage repairs

Body and paintwork repairs must be performed in accordance with guidelines issued by Chevrolet so that they meet the requirements for permanent corrosion protection and corrosion protection measures carried out on repair.

As faulty or inadequate repairs can be "concealed", we must exclude from the warranty areas of the vehicle where paintwork repairs have taken place.

Your Chevrolet Partner has the necessary qualifications, equipment and materials to perform corrosion protection measures properly. If necessary, after the repair, he/she will recommend further sensible measures to maintain the value of your vehicle.

Visual inspection and confirmations

When the vehicle is being checked, a visual inspection of the paintwork, bodywork and corrosion protection of the underbody is prescribed to check for damage. The customer will be notified in writing of any damage and its rectification. Any damage and confirmation of servicing carried out will be noted on the following pages.

Damage

Rectification of the damage observed is available at extra cost.

Separate service

The corrosion protection service is necessary even after expiry of the vehicle warranty in order to maintain the warranty against rust penetration.

16 Maintenance Records

The graphic is applicable to all models.

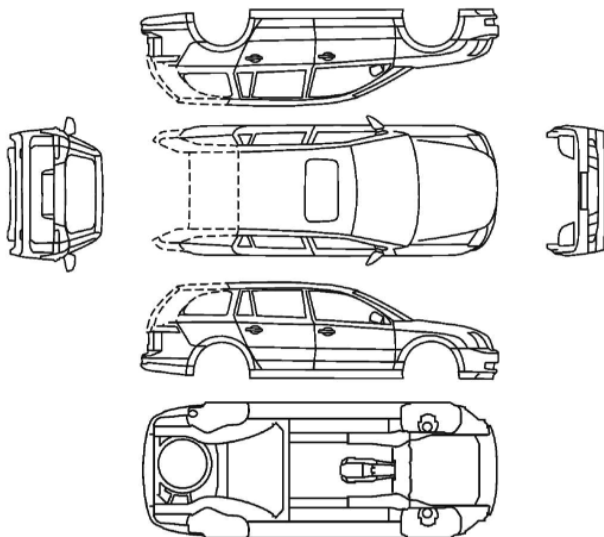

1. Inspection

Vehicle OK

Yes No

Vehicle repaired

Yes No

Accident / body damage repaired to Chevrolet guidelines

Yes No

Comments

Date

km

Partner stamp and signature

Mark test result using relevant symbol:

- Stone chips
- Dent/bump
- + Scratch
- Bodywork damage
- # Paintwork damage
- ▶ Underbody protection damaged

The graphic is applicable to all models.

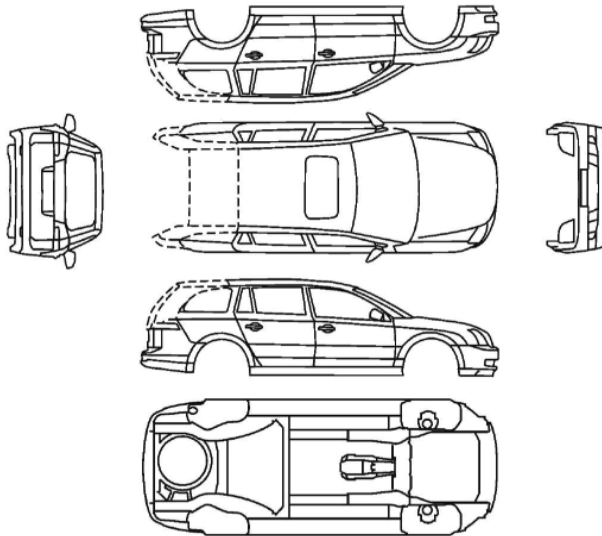

2. Inspection

Vehicle OK

Yes No

Vehicle repaired

Yes No

Accident / body damage repaired to Chevrolet guidelines

Yes No

Comments

Date

km

Partner stamp and signature

Mark test result using relevant symbol:

- Stone chips
- Dent/bump
- + Scratch
- Bodywork damage
- # Paintwork damage
- ▶ Underbody protection damaged

18 Maintenance Records

The graphic is applicable to all models.

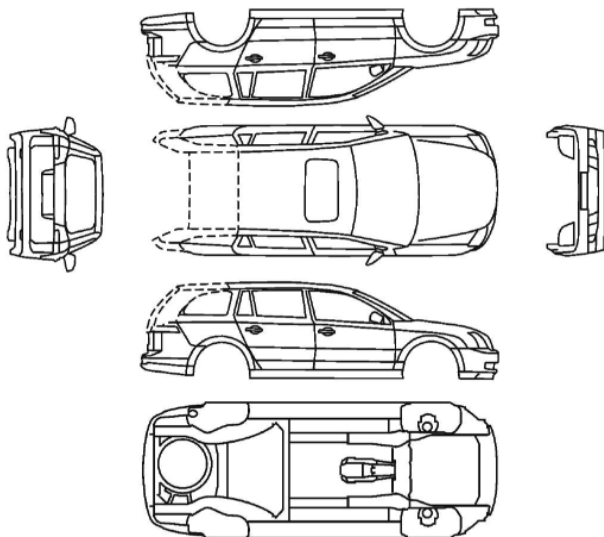

3. Inspection

Vehicle OK

Yes No

Vehicle repaired

Yes No

Accident / body damage repaired to Chevrolet guidelines

Yes No

Comments

Date

km

Partner stamp and signature

Mark test result using relevant symbol:

- Stone chips
- Dent/bump
- + Scratch
- Bodywork damage
- # Paintwork damage
- ▶ Underbody protection damaged

The graphic is applicable to all models.

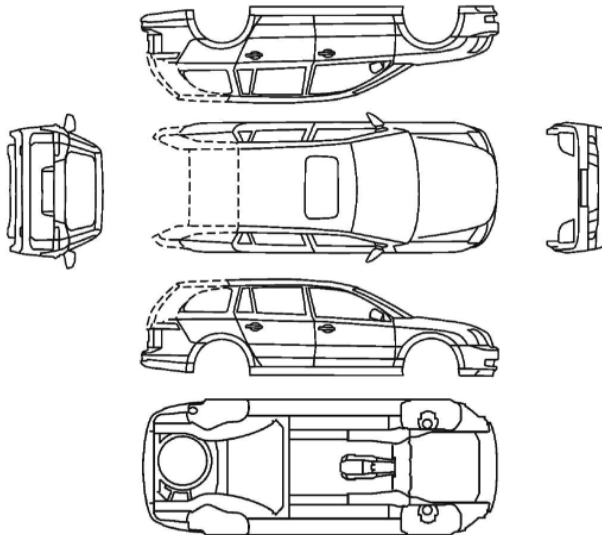

4. Inspection

Vehicle OK

Yes No

Vehicle repaired

Yes No

Accident / body damage repaired to Chevrolet guidelines

Yes No

Comments

Date

km

Partner stamp and signature

Mark test result using relevant symbol:

- Stone chips
- Dent/bump
- + Scratch
- Bodywork damage
- # Paintwork damage
- ▶ Underbody protection damaged

20 Maintenance Records

The graphic is applicable to all models.

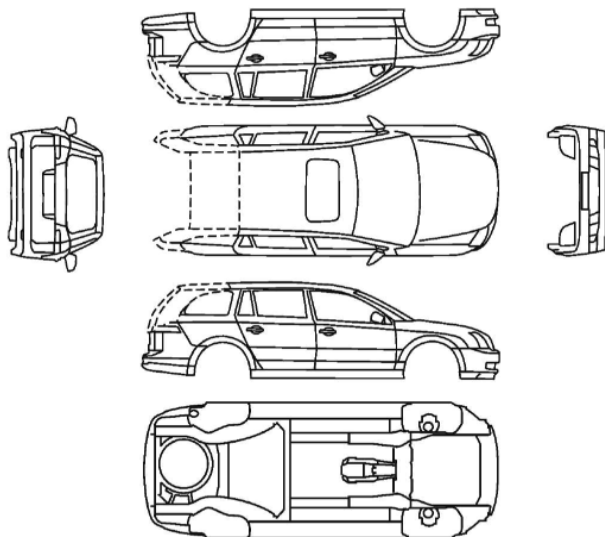

5. Inspection

Vehicle OK

Yes No

Vehicle repaired

Yes No

Accident / body damage repaired to Chevrolet guidelines

Yes No

Comments

Date

km

Partner stamp and signature

Mark test result using relevant symbol:

- Stone chips
- Dent/bump
- + Scratch
- Bodywork damage
- # Paintwork damage
- ▶ Underbody protection damaged

The graphic is applicable to all models.

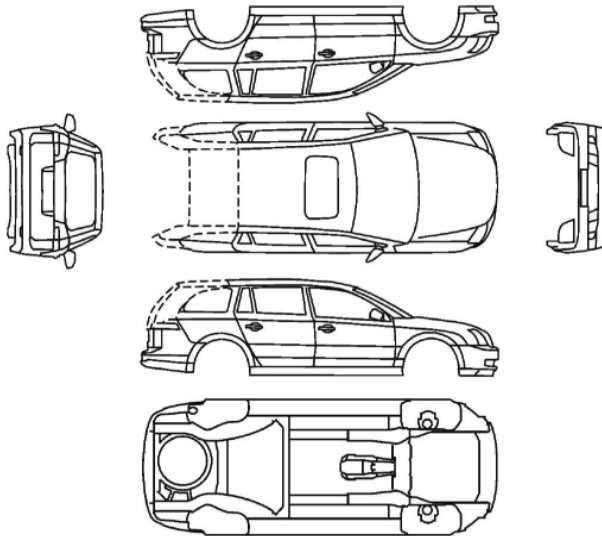

6. Inspection

Vehicle OK

Yes No

Vehicle repaired

Yes No

Accident / body damage repaired to Chevrolet guidelines

Yes No

Comments

Date

km

Partner stamp and signature

Mark test result using relevant symbol:

- Stone chips
- Dent/bump
- + Scratch
- Bodywork damage
- # Paintwork damage
- ▶ Underbody protection damaged

 **NOTES**

 **NOTES**



Copyright Cadillac Europe GmbH, Zurich, Switzerland

All information contained in this booklet is based on latest product information available at the time of printing, and is effective as of the date indicated below, Cadillac Europe GmbH reserves the exclusive right to modifications to this booklet.

Edition: June 2022, Cadillac Europe GmbH, Zurich, Switzerland

Printed on chlorine-free bleached paper.

